



# SHAVED-40

## INSTALLATION MANUAL & OPERATION INSTRUCTIONS

Our most popular kit comes complete with (1) seven-channel receiver, (2) remote transmitters and (2) solenoids with 40 pounds of pull each. This kit also includes all necessary hardware for installation. The SHAVED-40 kit offers enough pull to open virtually any door on the market today.

### LIMITED WARRANTY STATEMENT SPAL USA WARRANTY STATEMENT

SPAL USA warrants this product to be free from defects in material and workmanship for a period of one (1) year from the date of sale to the original purchaser, and not more than two (2) years from the date of manufacture. SPAL USA will repair this product free of charge if, in the judgment of SPAL USA, it has been proven defective within the warranty period. The product should be returned, at the customer expense, to the location of original purchase. This warranty does not cover any expenses incurred in the removal and/or reinstallation of the product. This warranty does not apply to any product damaged by improper installation, accidental misuse, abuse, improper line voltage, fire, flood, lightning, or other acts of God, or a product altered or repaired by anyone other than SPAL USA. This warranty is in lieu of other warranties, expressed or implied, including any implied warranty of merchantability. No person is authorized to assume for SPAL USA any other liability concerning the sale of this product.

IMPORTANT-KEEP YOUR INVOICE WITH THIS WARRANTY STATEMENT!



1731 SE Oralabor Road • Ankeny, IA 50021  
Sales: 800-345-0327 • Fax: 800-654-7725  
Tech Support Line: 800-454-7725 (M-F / 8am - 5pm CST)  
tech@spalusa.com • www.spalusa.com

JayCorp Technologies  
Order at [www.jaycorpotech.com](http://www.jaycorpotech.com)  
866-529-2677



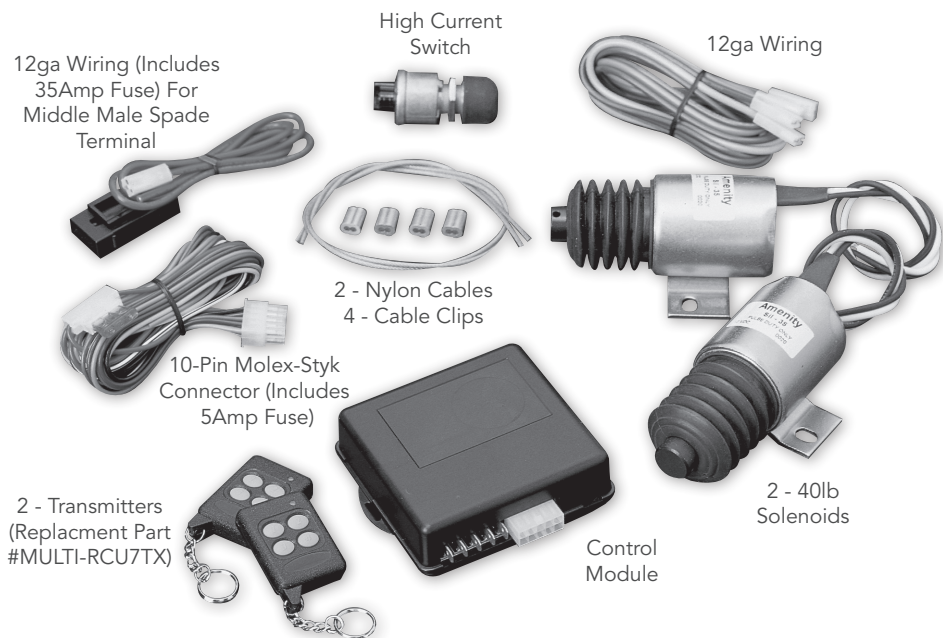

### Accessories

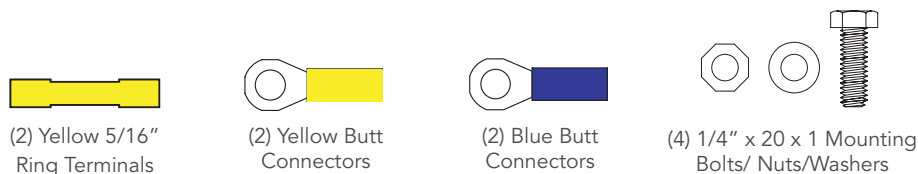

### FUNCTIONALITY:

The SHAVED-40 is designed to operate up to 7 functions. Channels 1 and 2 are controlled by 2 on-board relays (see page #2 for output locations). Channels 3 through 7 are controlled by negative output wires (see page #2 for output locations) supplied to external relays (not provided).

### FEATURES:

- 1) Control module can hold up to (4) key fobs (transmitters) with different signals.
- 2) Control module incorporates a lock pulse timer that provides a .4 second pulse from the control module to the device(s). If the buttons on the key fob (transmitter) are held down for an extended period, the lock pulse timer will prevent the device(s) from being damaged.
- 3) Control module incorporates a time-out feature that eliminates damage to the device(s) by shutting down the system for 30 seconds if the buttons on the key fob (transmitter) are activated more than 8 times in a 30 second period. After the 30 second time-out period, the system will function as normal.
- 4) Key fob (transmitter) has a range of 150' maximum.

### >>> PLEASE NOTE! <<<

**Power and ground to the 10-PIN connector must be hooked up to the control module for the unit to operate correctly!**

### OPERATION:

#### 10-PIN MATING CONNECTOR 9357-10

CAVITY	CIRCUIT	WIRE COLOR	FUNCTION
1	Ground	Black	To Ground
2	Not Used	Green	---
3	Channel 7	Purple	Negative Output
4	Channel 5	Blue	Negative Output
5	Channel 3	Orange	Negative Output
6	+12V	Red	To Power
7	Ignition	Yellow	To Ignition Power
8	Not Used	Grey	---
9	Channel 6	White/Black	Negative Output
10	Channel 4	Brown	Negative Output

#### SPADE TERMINALS (POSTION 1 IS CLOSEST TO 10-PIN CONNECTOR) MATING CONNECTOR .250" FEMALE TERMINAL

POSITION	CIRCUIT	WIRE COLOR
1	Not Used	Violet
2	Not Used	Orange
3	12V	Red
4	Channel 1	Brown
5	Channel 2	Yellow

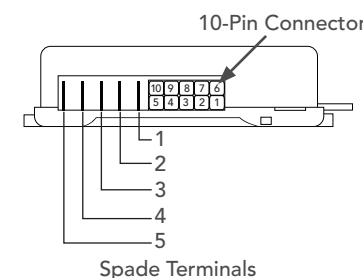
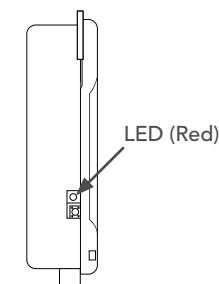
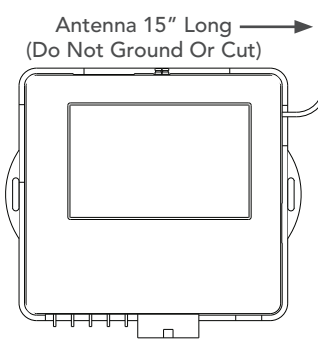

## PROGRAMMING:

- 1) The SHAVED-40 kit can accept up to (4) transmitters. Kit comes complete with (2). Replacements can be ordered under SPAL part #MULTI-RCU7TX.
- 2) The transmitters that come with the SHAVED-40 kit are pre-programmed to the main module/receiver.
- 3) In the event that a remote is lost or if you wish to add more transmitters, follow these instructions:
  - A) Make sure the ignition is turned off.
  - B) Locate the programming button on the side of the receiver, next to the led.
  - C) Press the programming button quickly 3 times. The led will light steady.
  - D) Press button #1 on each transmitter you wanted learned into the receiver (one at a time and you will have approximately 10 seconds to complete the learning procedure. The led will flash each time a transmitter has been successfully programmed.
  - E) After the last transmitter has been programmed, wait for the led to go out. Then test each transmitter for proper functioning.

## JUMPER, DIP SWITCH SETTINGS & TRANSMITTER SETTINGS:

All dip switches to be in the "off" position

<b>BUTTON #1</b>	<b>Programmed to control module</b>	<b>BUTTON #2</b>
Pushing operates the lock function - channel 1		Pushing operates the unlock function - channel 2
<b>BUTTON #3</b>		<b>BUTTON #4</b>
Pushing operates the function for channel 3		Pushing operates the function for channel 4

**ADDITIONAL CHANNELS**

**BUTTON #1 & #2**  
Pushing simultaneously operates the function for channel 5

**BUTTON #1 & #3**  
Pushing simultaneously operates the function for channel 6

**BUTTON #1 & #2**  
Pushing simultaneously operates the function for channel 7

\*BATTERIES INCLUDED  
Replacement batteries can be ordered from:  
GP27A / LR23A  
[www.radioshack.com](http://www.radioshack.com)

## MOUNTING & WIRING:

- 1) The control module/receiver must be mounted inside the vehicle to avoid moisture.
- 2) Do not plug in the control module/receiver until all the wiring is complete.
- 3) When using the SHAVED-40 control module with SPAL actuators (instead of the 40lb solenoids) replace the 35amp fuse with a 10amp fuse (not supplied).
- 4) DO NOT ground the solenoid to the door. Extend the ground lead to a good chassis ground. Reason being, grease on the door's hinge may not allow for a good ground.
- 5) **Connecting the yellow ignition wire will disable channels 1-4 while the ignition is on.**

## EMERGENCY-BACKUP SWITCH (INCLUDED IN KIT):

- 1) It is **STRONGLY RECOMMENDED** that an emergency-backup switch be mounted outside the vehicle in the event of lost transmitters, loss of power or your keys get locked inside the vehicle.
- 2) See the suggested wiring diagram:

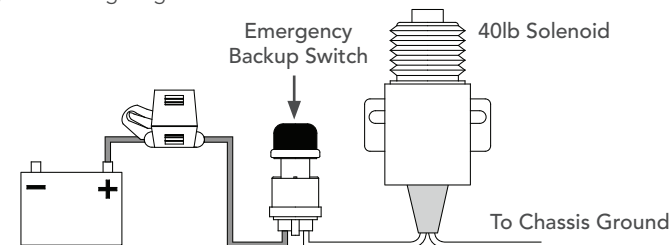

### RECOMMENDATION:

Locate 35amp Fuse/Fuse Holder Within 18" Of Battery.  
Fuse Holder Not Supplied & Must Be Purchased Separately.

## MOUNTING / WIRING:

- 1) Attach the WHITE WIRE of the DRIVER DOOR solenoid to the BROWN WIRE (large gauge/channel 1, from spade connector harness) of the receiver.
- 2) Attach the WHITE WIRE of the PASSENGER DOOR solenoid to the YELLOW WIRE (large gauge/channel 2, from the spade connector harness) of the receiver.
- 3) Connect the remaining BLACK WIRE of the solenoid to a ground located on the vehicle body. (The door is not a proper grounding source!)

**\*\*A mechanical backup switch should be utilized in case of power failure.\*\***

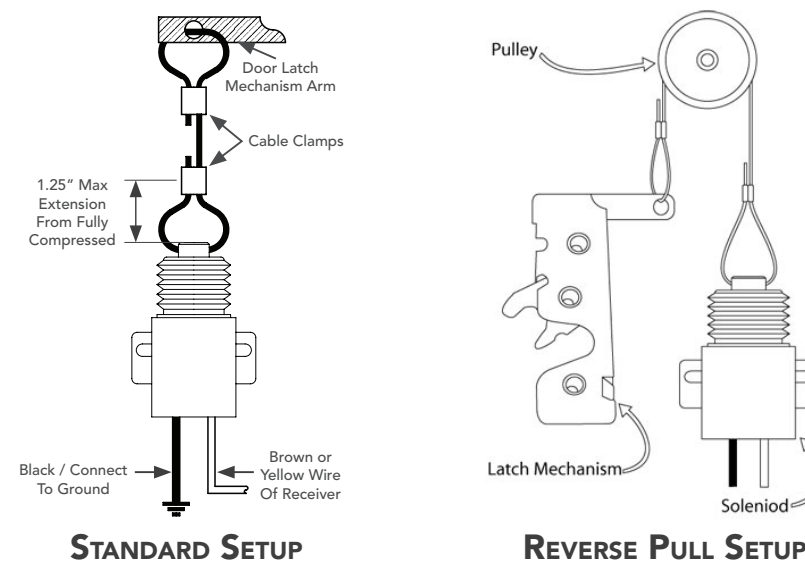

## WIRING OPTIONS FOR CHANNELS 3 THROUGH 7:

ITEM TO BE ACTIVATE	DESCRIPTION OF FUNCTION	RELAY TYPE	# OF RELAYS REQUIRED	DIAGRAM
1 Power Window Motor	Move Window Up & Down	SPDT	2	Reverse
1 Power Window Motor	Move Window Up & Down	SPDT	1	Reverse
Linear Actuator	Move In & Out	SPDT	2	Reverse
Solenoid	Activate Solenoid	SPST Or SPDT	1	Positive Or Negative
Trunk Release	Open The Trunk	SPST Or SPDT	1	Positive Or Negative
Door Lock Actuator	Lock & Unlock	SPDT	2	Reverse

**SPST** / Single pole single throw relay, 30amp or 40amp.

**SPDT** / Single pole double throw relay, 30amp or 40amp.

Relays can be purchased from SPAL USA (Part #HR-SC-RELAY) or from your local auto parts store.

### POSITIVE OUTPUT:

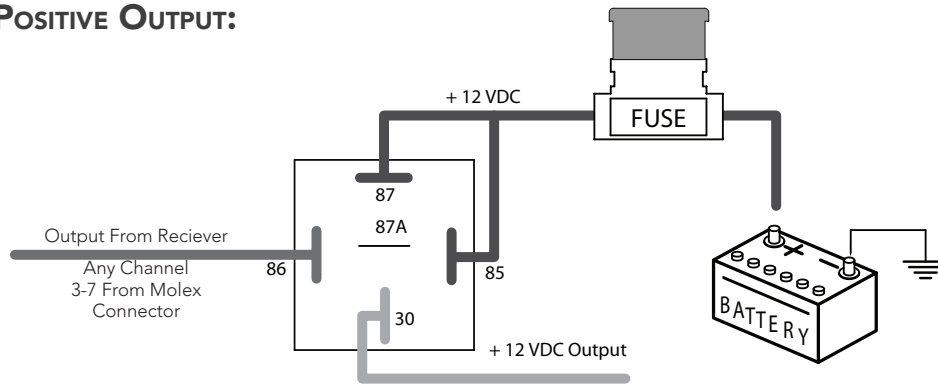

### NEGATIVE OUTPUT:

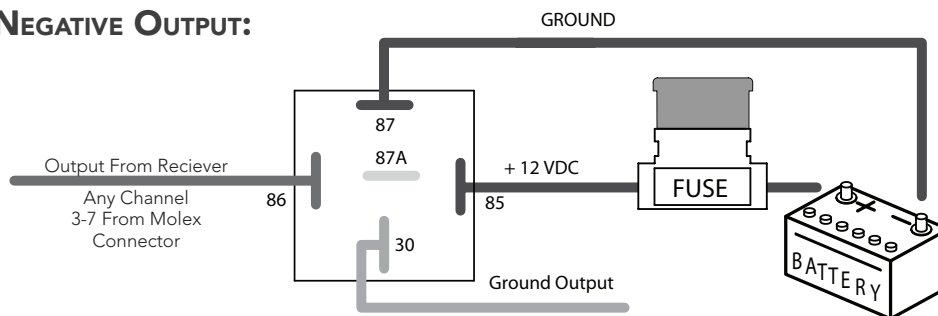

## WIRING OPTIONS FOR OPENING TRUNK USING YOUR SHAVED-40:

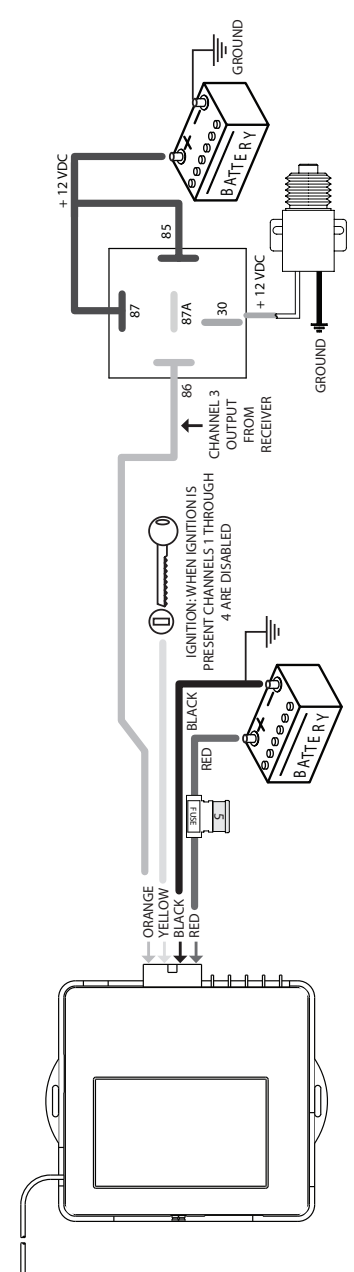

### POSITIVE TRUNK RELEASE SOLENOID:

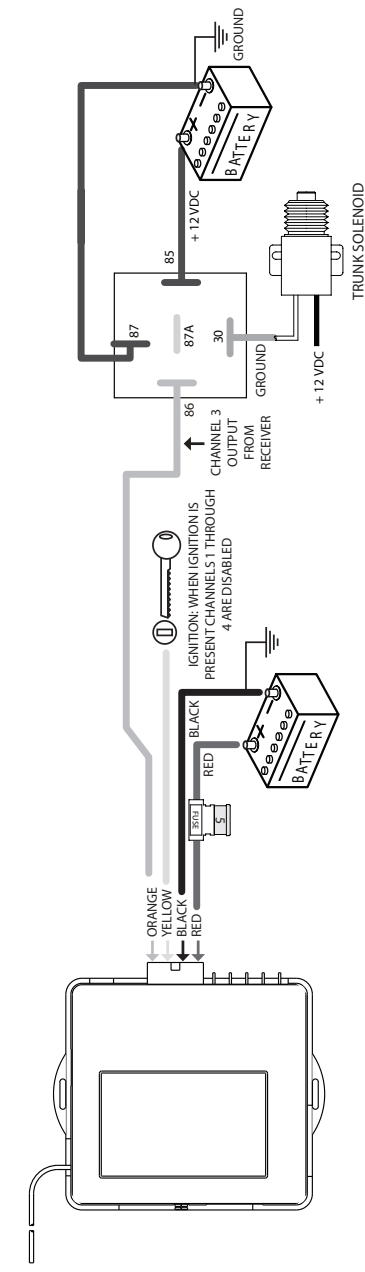

### NEGATIVE TRUNK RELEASE SOLENOID:

## REVERSE POLARITY OUTPUT:

**\*\*IN A REVERSE POLARITY SYSTEM, A SWITCH THAT RESTS AT GROUND MUST BE USED!\*\***

For power windows, two relays must be placed between the switch and the window motor. The dashed line indicates where the wires must be cut.

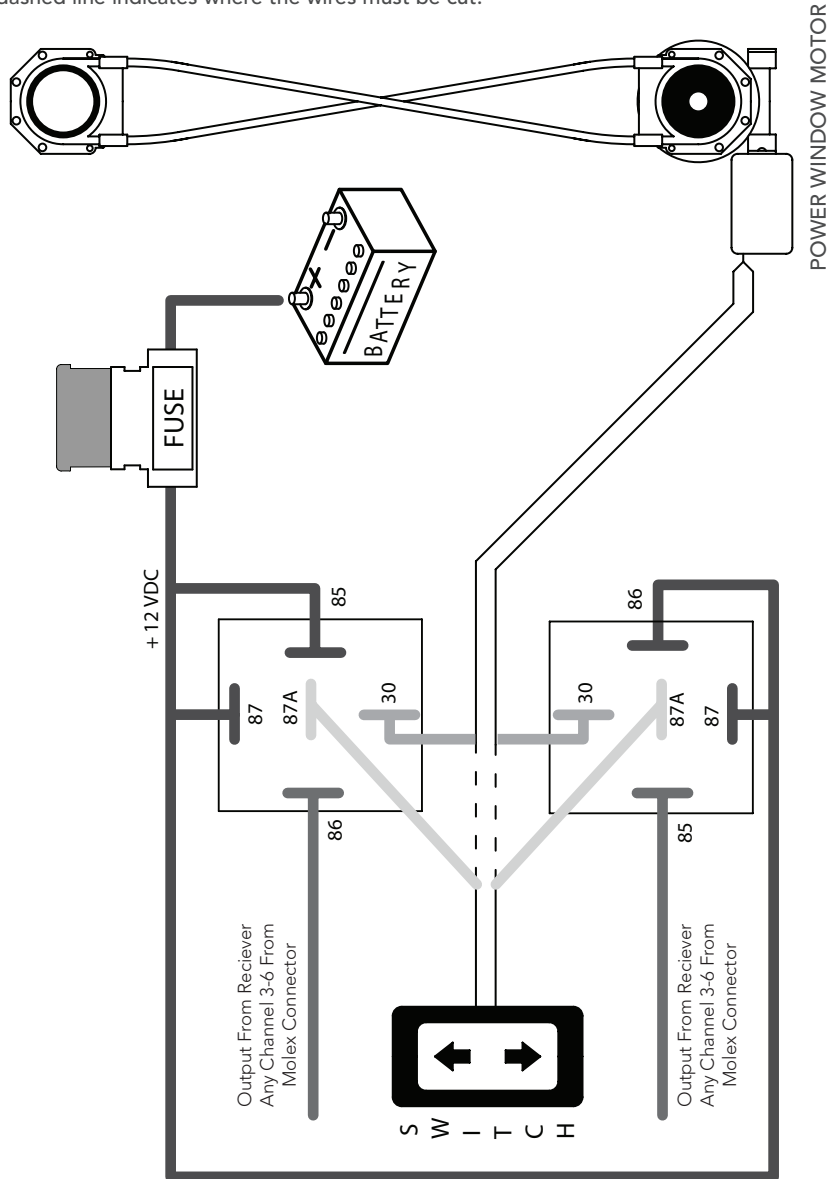

## MINIMUM INSTALL REQUIREMENTS:

